

Lateral Surface Area

The lateral (side) surface area of a solid of revolution includes only its side, not its top or bottom. For example, the lateral surface area of a soup can is the area of the label.

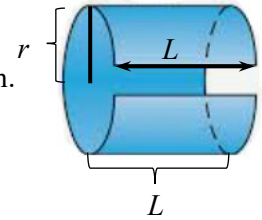

1. Complete the boxes to report the lateral surface area of a soup can with radius r and length L from top to bottom.

Lateral Surface Area =

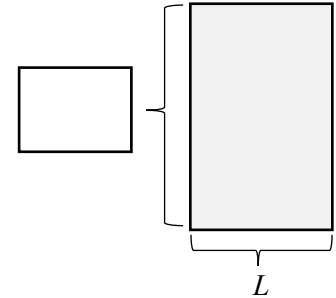

2. Report the **arc length** L of any function $y = f(x)$ from $x = a$ to $x = b$.

$$L = \int_{\square}^{\square} \left(\square \right) d\square$$

Decide x or y

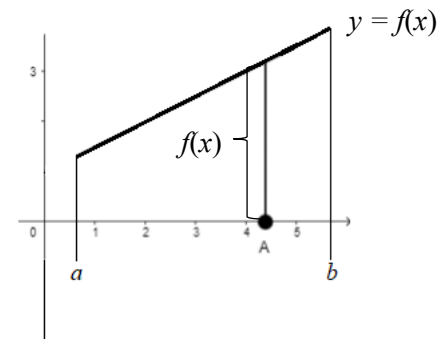

3. Report the **lateral surface area** LSA created by revolving any continuous, differentiable function $y = f(x)$ about the x -axis from $x = a$ to $x = b$, assuming $f'(x)$ is continuous.

$$LSA = \int_{\square}^{\square} \left(\square \right) d\square$$

Decide x or y

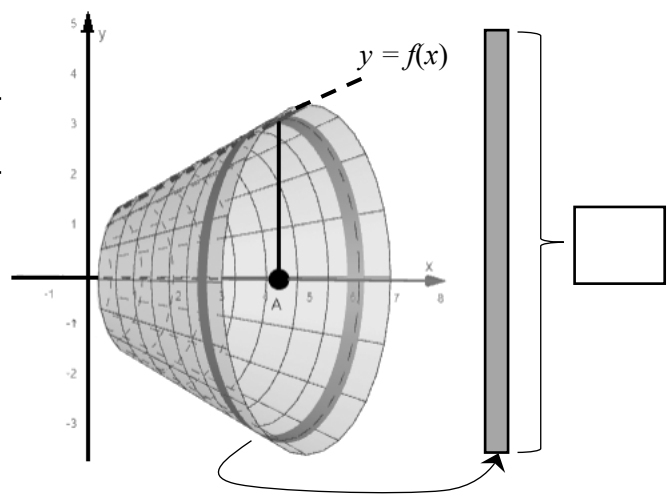

4. Heinz is shown below with his water dish. Use the FTC to set up and find its **exact lateral surface area**. Use the FTC to find the **exact volume**.

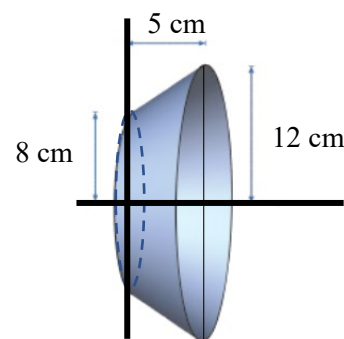

Cool fact: The **lateral surface area LSA** created by revolving any continuous, differentiable function $x = g(y)$ about the y -axis from $x = c$ to $x = d$, assuming $g'(y)$ is continuous would be

$$\int_c^d 2\pi g(y) \sqrt{1 + (g'(y))^2} dy = \int_c^d 2\pi g(y) \sqrt{1 + \left(\frac{dx}{dy}\right)^2} dy$$

Rhino Participation Bonus (+2): Set up a definite integral and use the FTC to show the LSA of the cone is $LSA = \pi rL$ and the volume is $V = \frac{1}{3} \pi r^2 h$. You can integrate with respect to x or y .

