

AC 2009-564: A GREENLITE SYSTEM: AN EFFICIENT SOLAR ENERGY SOLUTION USING A SUN TRACKER PANEL AND A LIGHT HARVESTING CONTROL PANEL

Zesheng Chen, Florida International University

Zesheng Chen is an Assistant Professor at the Department of Electrical and Computer Engineering at Florida International University. He received his M.S. and Ph.D. degrees from the School of Electrical and Computer Engineering at the Georgia Institute of Technology in 2005 and 2007. He also holds B.E. and M.E. degrees from the Department of Electronic Engineering at Shanghai Jiao Tong University, Shanghai, China in 1998 and 2001, respectively. His research interests include network security and the performance evaluation of computer networks.

Erik Pazos, Florida International University

Erik Pazos is currently working as an Electrical Estimator at Hypower Inc. He achieved a Bachelors Degree in Electrical Engineer this past December 2008. He also achieved Associated in Arts Degree in Summer 2006. With his early age of 25 years old, he has manage to gain 6 year of experience in the construction field; where he has learn the great values and principles of Electrical work. He is currently attending an electrical apprenticeship school to exceed his understanding his knowledge in the Electrical field. He also posses the knowledge of some essential programs in the construction industry.

Darian Garcia, Florida International University

Dayron Garcia, Florida International University

Julio Duharte, Florida International University

Julio Duharte will receive his B.S. in Computer Engineering from the School of Electrical and Computer Engineering at Florida International University in May 2009. His research interests include web applications, embedded programming and computer networks. Currently working for Discovery Cruise Line as Communications Assistant.

A GreenLite System: An Efficient Solar Energy Solution Using a Sun Tracker Panel and a Light Harvesting Control Panel

Abstract

Reducing high energy consumption and costs is imperative and significant to our daily life. In this paper, we describe a capstone senior design project that develops an efficient energy-saving solution. The solution is called the *GreenLite* system and consists of two components: a self-adjustable solar tracker panel and a light harvesting control panel.

The solar tracker panel tends to maximize the absorption of solar power. Specifically, the solar tracker panel can adjust itself automatically to the direction where the panel is directly facing the Sun. To achieve this, the component employs photo-sensors to measure the irradiance of the Sun and to provide the feedback signal on the current position of the panel. The component also uses actuators that contain motors to rotate the panel at all possible angles.

The light harvesting control panel designs a dimming fluorescent lighting system. Specifically, the system tends to reduce energy demand by dimming lights proportional to the amount of daylight received, based on the measurements from photo-sensors. Moreover, this control panel is powered by the energy obtained from the solar tracker panel.

In the project, the microcontroller dsPIC30F4011, programmed by C++ language, is used to control the motors on the actuators. The system is also designed as sturdy and lightweight as possible for increased durability and mobility. The details of the implementation are given, and the lessons learnt are discussed.

Introduction

In recent years, there have been increased interest and demand in reducing high energy consumption, avoiding environment pollution, and finding alternative energy. Solar energy is such an ideal alternative. First, solar energy provides a sustainable source for generating power and thus satisfies high energy consumption demand. Second, solar energy is green and can potentially free us from depending on polluting non-renewable sources such as coal, oil, and gas. Last, solar energy is free and can reduce the cost. Therefore, we study an efficient energy serving solution using solar energy in our capstone senior design project.

Our solution is called the *GreenLite* system and consists of two components:

- **A self-adjustable solar tracker panel.** The solar track panel transforms solar energy into stored electrical power. Our designed solar tracker panel tends to maximize the absorption of solar power. Specifically, the solar tracker panel can adjust itself automatically to the direction where the panel is directly facing the Sun.
- **A light harvesting control panel.** The control panel designs a dimming fluorescent lighting system. Specifically, the system tends to reduce energy demand by dimming lights

proportional to the amount of daylight received. Moreover, this control panel is powered by the energy obtained from the solar tracker panel.

In the project, the GreenLite system employs the photo-sensor technology to detect the position of Sun and sense the lightness in a room. The microcontrollers (*i.e.*, dsPIC30F4011) programmed by C++ language are used to collect the signals from sensors, and then control the motors on the actuators to adjust the solar tracker panel or direct the LEDs in rooms to the corresponding level of brightness. The system is designed as sturdy and lightweight as possible for increased durability and mobility. As a result, the saving of using daylight harvesting is about 35-60%.

Due to the complexity of this senior design project, we formed a team from multidisciplinary areas of engineering. Specifically, the team was composed of three electrical engineers and one computer engineer. All electrical engineers were mainly in charge of the hardware and mechanical designs, whereas the computer engineer worked on programming the microcontrollers.

The remainder of this paper is structured as follows. We first briefly introduce the capstone senior design courses and the related work, and then describe our designed GreenLite system in detail. We further discuss some lessons learned from this project. Finally, we conclude this paper.

Capstone Senior Design Courses

The expected outcomes of the capstone senior design project include an ability to design a system, component, or process to meet desired needs, an ability to function on multi-disciplinary teams, an ability to identify, formulate, and solve engineering problems, an understanding of professional and ethical responsibility, an ability to communicate effectively, and a knowledge of contemporary issues.

To help students achieve these goals and perform senior design projects, Department of Electrical and Computer Engineering at Florida International University provides two courses in two consecutive semesters: EEL 4920 (Senior Design I) and EEL 4921 (Senior Design II). Specifically, EEL 4920 gives comprehensive lectures, providing the overview of a senior design project, the methodologies for developing a project, the considerations of ethics, intellectual properties, standards, health, and safety, and the design tools for using microcontrollers. In this course, students need to define an appropriate project and create a prototype design. Moreover, at the very early stage of the project, students have to find a faculty member as their advisor for their project.

EEL 4921 emphasizes the interaction between students and the faculty, and focuses on the implementation of the project. Students meet with the faculty periodically to discuss the difficulties encountered and document their progress. At the end of EEL 4921, there is a public section for presenting the senior design projects to all faculty and students in the department and people from the board of trustees. The board of trustees and faculty members evaluate the projects based on the quality of the design and the implementation.

Related Work

In this section, we review related work on solar trackers and the technologies used for daylight harvesting.

US patent 6239353¹ and patent 4649899² give two solar trackers and use heat transducers or solar cells to track the Sun. Comparatively, we apply photo-diodes in our work to more accurately locate the position of the Sun.

Many companies have developed the technologies and products on daylight harvesting. For example, Easylite³, Lighting Control & Design⁴, and California Lighting Technology Center⁵ have studied different lighting control technologies to save energy. Their work has inspired us to apply photo-sensors in our design.

GreenLite System

System Design

The modules of the GreenLite system are shown in Figure 1. Specifically, we design the system from two aspects: control and hardware. The “control” module focuses on the software design (using C++ language) that relates to operating the components such as LEDs, sensors, and IC chips; whereas the “hardware” module covers the selection and the construction of different devices such as joints, actuators, the solar panel, and bright LEDs. In this project, we have chosen universal joints, linear actuators, and the CIS/ThinFilm solar panel, based on the cost and the performance considerations. In the following, we detail the design of the solar tracker panel and the light harvesting control panel.

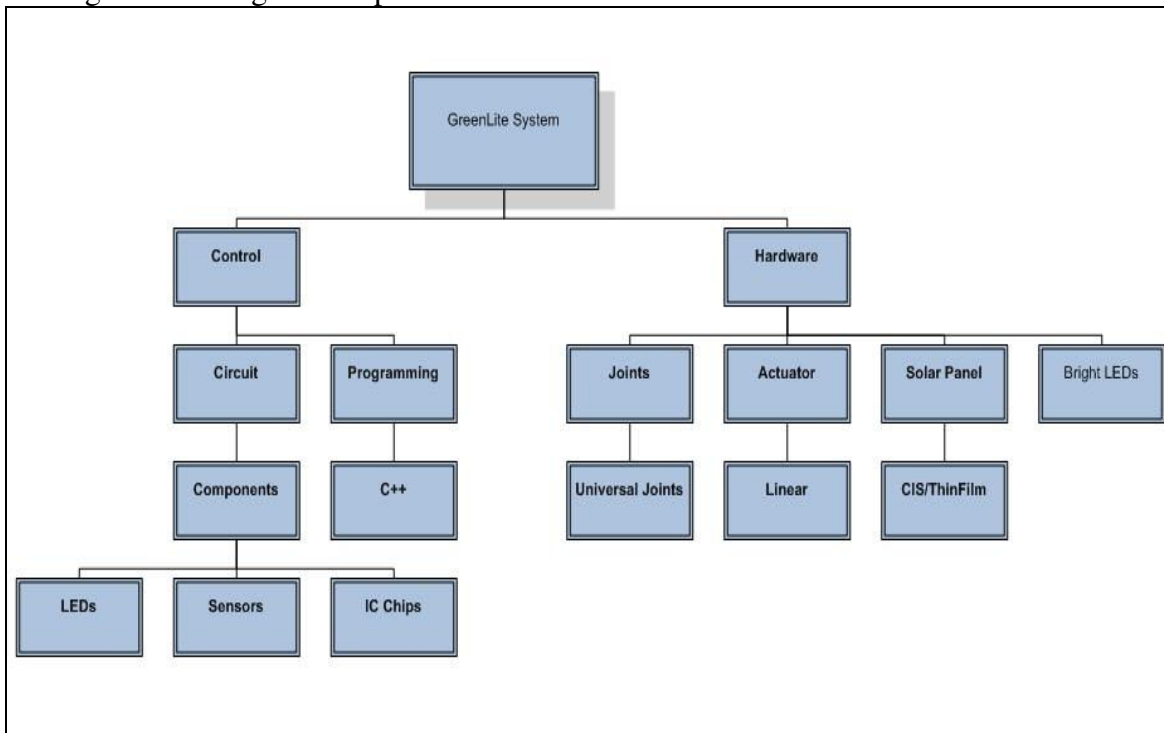

Figure 1: Design modules of the GreenLite system

Solar Tracker Panel

The modular structure of the solar tracker panel is shown in Figure 2. Specifically, the solar energy is collected and stored in a 12V battery. The battery in return serves as the power supply to other circuits and the light harvesting control panel. We apply 9 photo-sensors to sense the position of the Sun and provide the corresponding signals to the microcontroller (or MCU). Based on such signals from sensors, the MCU controls the motion of 3 linear actuators to go up and down until the panel has a 90 degree with the direction of the Sun. The control structure between the MCU and actuators is shown in Figure 3.

The main difficulty in designing the solar tracker panel is how the photo-sensors sense the current position of the Sun. To resolve this challenge, we design the panel in the following way. Each sensor is connected to the collector of a BJT transistor. Moreover, the 9 sensors are installed in a 3×3 matrix. The matrix is covered by a black tube with a small hole in the top. When the panel has a 90 degree with the Sun, the beam of the light would get through the small hole and hit the center sensor; and as a result, the actuators would not move. When the panel does not have a 90 degree with the Sun, the beam of the light would hit other sensors, which send signals to the MCU so that the MCU would control the actuators to move the panel to the right position. The circuit with the sensors and the MCU is shown in Figure 4.

Moreover, our design solar tracker panel is demonstrated in Figure 5. Through testing, we find that our solution is effective and the panel can really track the position of the Sun.

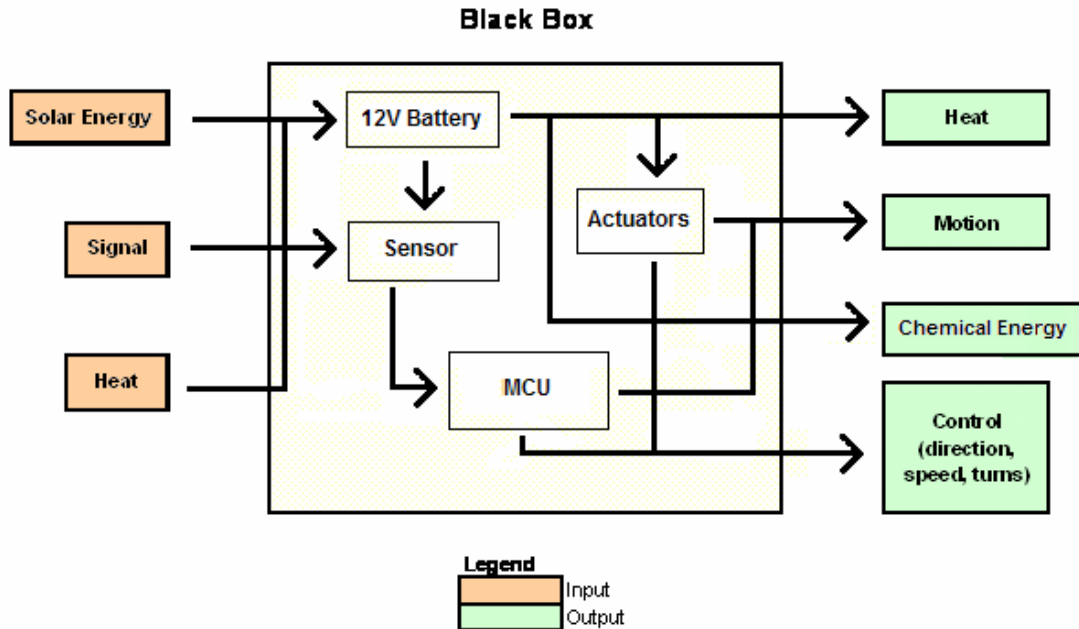

Figure 2: Design modules of the solar tracker panel

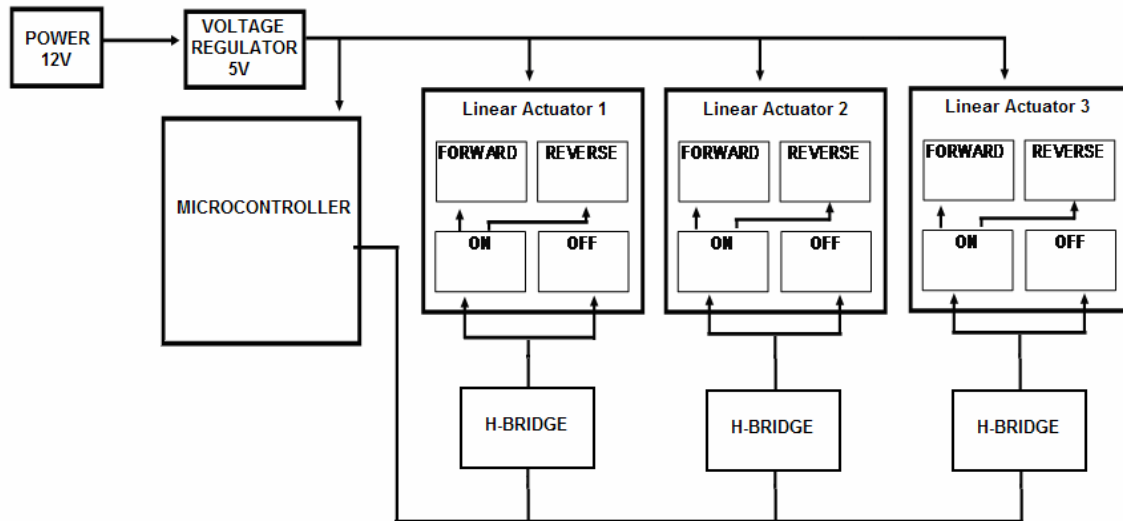

Figure 3: Control structure between the MCU and actuators

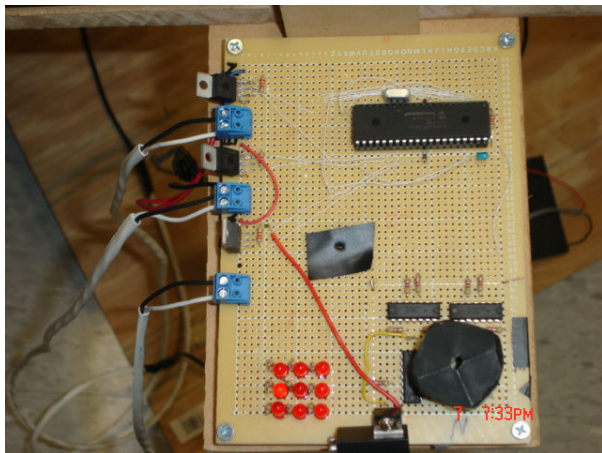

Figure 4: Circuit with the 9 sensors and the MCU



Figure 5: Solar tracker panel

Light Harvesting Control Panel

In the light harvesting control panel, we use the same photo-sensors as those in the solar tracker panel to sense the lightness in rooms. We also use the bright emitting diodes instead of regular LEDs and bulbs for that the bright emitting diodes are more durable and inexpensive, and meanwhile provide the necessary light for this project.

Similar to the structure of the solar tracker panel, the light harvesting control panel applies sensors to determine the current lightness in rooms and send the signals to the MCU. After obtaining the feedback signals from sensors, the MCU compares the current lighting value with a given value and then adjusts the lightness of the bright emitting diodes accordingly. Therefore, if in a room there is sufficient lightness from outside (*i.e.*, the light from the Sun), the diodes will be turned off automatically. Otherwise, the diodes will be adjusted to the right intensity based on the current lighting condition.



Figure 6: Back and front of a small wooden house for illustrating the light harvesting system

To evaluate and test our GreenLite system, we have built a small wooden house as illustrated in Figure 6. The house has 4 rooms; and each room has been installed our designed lighting control system, which is powered by our designed solar tracker panel. We found that compared with the regular lighting system, our GreenLite system has an energy saving of about 35-60%.

Observations

This capstone senior design project lasted two semesters and implemented the GreenLite system successfully. However, we have learnt several lessons from this project:

- **Material selection.** Materials in this project include motors, the solar panel, battery, sensors, LEDs, elbow joints, and wood. How to select the right materials is a key issue at the early stage of the project. There is always a tradeoff between the cost and the desired performance. The total cost of the entire project is about \$800, which is a little higher than the original expectation. We could do more research on the potential materials to decrease the cost, for example, using a different battery type or using the plastic material instead of wood to build the house model.
- **Protection circuits.** Sensors and electronic hardware have certain current and voltage limitations. We ignored this at the early design stage; and as a result, we have encountered shorting and burnt some circuits. The safety of the design should be considered from the very beginning.
- **House model build-up.** Our students have spent too much time on building the house model. If possible, we should search for help from the Department of Construction Management for this or demonstrate the GreenLite system in a different, but easier way.

Conclusions

In this capstone senior design project, we have successfully designed and implemented a GreenLite system, which consists of a solar tracker panel and a light harvesting control panel. Our GreenLite system is shown to be able to utilize the available daylight to reduce the amount of electrical lights in a house. The system is also designed as sturdy and lightweight as possible for increased durability and mobility.

Our students have met the expected outcomes of the capstone senior design project. Moreover, the experience of building the GreenLite System has introduced our students to the world of alternative energy sources and may impact their life-long learning.

Bibliography

1. US Patent 6239353, [Online]. <http://www.freepatentsonline.com/6239353.html> (February/2009 accessed).
2. US Patent 4649899, [Online]. <http://www.freepatentsonline.com/4649899.html> (February/2009 accessed).
3. EasyLite Integrated Lighting Systems, [Online]. <http://www.easylite.org/> (February/2009 accessed).
4. Lighting Control & Design, [Online]. <http://www.lightingcontrols.com/> (February/2009 accessed).
5. California Lighting Technology Center, [Online]. <http://cltc.ucdavis.edu/content/view/85/87/> (February/2009 accessed).